

● Electricity

- In case of using the Rental Display System, it is not required to submit "Electrical Service (I)".
- The Rental Display System includes basic electrical service. In case you need extra lighting, it is required to fill in "Electrical Service (II)" to apply.
- If you require extra lighting, note that the additional primary wiring and branch circuit construction is required, regardless of the current wiring circuit construction and electrical consumption.
- Exhibitors are requested to refrain from bringing their own lighting equipment to avoid any electrical trouble on site. If there are any other items you require, contact the official contractor directly.
- Total price is calculated by adding the amount in (A), (C) and (D). Amount in (C) and (D) depend on the wattage of the lighting equipment you order.
- Amount indicated in (C) includes both construction and electricity consumption charge.
- Amount in (C) and (D) will be automatically charged according to the equipment you order. The period or the span in which the electricity is consumed is irrelevant. e.g. Either when the electricity was consumed from 8:00am (move-in time) or from 10:00am, the amount charged in (C) and (D) will be the same.

Rental Lighting Equipment Catalogue

1 Fluorescent Lamp
JPY4,840

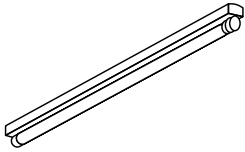

2 Spotlight with arm
Light bulb color: JPY6,050
Daylight color: JPY6,050



3 Spotlight
Light bulb color: JPY5,445
Daylight color: JPY5,445

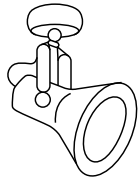

4 LED 30W (Daylight Color)
JPY12,100

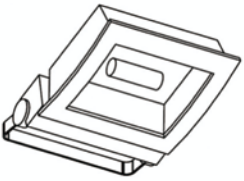

5 Outlet 100V up to 1.5kW
JPY3,630

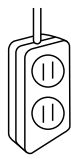

6 LED 60W (Daylight Color)
JPY21,780

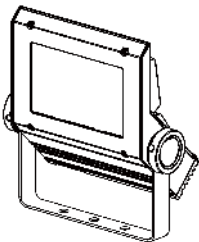

*10% consumption tax included.

*Order these equipment by submitting the form "Electrical Service (II)".

MUST SUBMIT

Electrical Service (I)

Send this Form to:	SUZUKI DENKI Co., Ltd. Contact: Ms. Arai / Mr. Toda TEL: +81-3-3842-8201 E-mail: medical-jpn@suzukidenki.co.jp	DEADLINE Sep. 13 (Fri)
	Show Title:	
Company Name:		
Contact (Mr./Ms.):		TEL:
E-mail:		

For exhibitors who do not apply for the Rental Display System, it is required to apply for this service to use electricity in your booth. Please fill in the blanks below and submit via E-mail.

Summary of Total Cost:

Sub-Total of (A)	JPY
Sub-Total of (C)	JPY
Sub-Total of (D)	JPY
Grand Total (A)+(C)+(D)	JPY

Primary Wiring Service for:

- Space Only Exhibitors
- Rental Display System Exhibitors who request a different power supply

100V single phase	50Hz		kW	JPY
200V single phase	50Hz		kW	JPY
200V three phase	50Hz		kW	JPY

Position

- Please specify the position of the main switch or submit a booth layout which indicates the position of the main switch.

Symbol of Main Switch <input type="checkbox"/> 100V <input type="checkbox"/> 200V single phase <input type="checkbox"/> 200V three phase	
--	---

Send confirmation of order to:

Name:	TEL:
E-mail:	

Send invoice to:

Name:	TEL:
Company:	E-mail:

Payment to be made via:

- Japanese yen (cash) Credit card (AMEX, VISA or Master)

Notes for Application:

- Forward all inquiries via **E-mail**. (See the contact details above.)
- Submit a **booth layout** which indicates all of your equipment and wattage per each.

< **SUPPLY HOURS** >

The 2nd day of move-in	noon – 10:00pm
The 1st day of the show	8:00am – the end of the show
The 2nd day of the show	8:30am – the end of the show
The last day of the show	8:30am – the end of the show

*Contact directly to the contractor for early / late electrical supply or any other inquiries.

Method of Payment	Official contractor will visit your booth to collect payment during the show period either in Japanese yen (cash) or the following credit cards (AMEX, VISA or Master).
--------------------------	---

Electrical Service (II)

Send this Form to:

SUZUKI DENKI Co., Ltd.
 Contact: Ms. Arai / Mr. Toda
 TEL: +81-3-3842-8201
 E-mail: medical-jpn@suzukidenki.co.jp

DEADLINE
Sep. 13 (Fri)

Show Title:	Booth #: -
Company Name:	
Contact (Mr./Ms.):	TEL:
E-mail:	

Your electrical contractor: _____

Person in charge: Mr./Ms. _____ TEL: _____

Connections at 100V (Secondary Wiring)

*10% consumption tax included

Lighting Equipment	Amount*	Watts
1. Fluorescent Lamp	JPY 4,840 × pcs.= JPY	pcs.= W
2. Spotlight with arm (<input type="checkbox"/> Light bulb color / <input type="checkbox"/> Daylight color)	JPY 6,050 × pcs.= JPY	pcs.= W
3. Spotlight (<input type="checkbox"/> Light bulb color / <input type="checkbox"/> Daylight color)	JPY 5,445 × pcs.= JPY	pcs.= W
4. LED 30W (Daylight color)	JPY 12,100 × pcs.= JPY	pcs.= W
5. Outlet 100V up to 1.5kW	JPY 3,630 × pcs.= JPY	(W) × pcs.= W
6. LED 60W (Daylight color)	JPY 21,780 × pcs.= JPY	pcs.= W
Total Amount (A) = JPY		Total Watts (B) = W

*Please contact the contractor when you need outlets for 200V.

Primary Wiring
↓

Branch Circuit Construction
↓

Total Watts (B)	Amount (C)
under 1kW	JPY 13,200
1.01~2.0kW	JPY 26,400
2.01~3.0kW	JPY 39,600
3.01~4.0kW	JPY 52,800
Above 4.01kW	JPY 13,200/1.0kW

Total Watts (B)	Amount (D)
under 1.5kW	JPY 6,050
1.51~3.0kW	JPY 12,100
3.01~4.5kW	JPY 18,150
4.51~6.0kW	JPY 24,200
Above 6.01kW	JPY 6,050/1.5kW